

PILOT OPERATED STOP VALVES

PSV15

Gas or Liquid

500 Bar Maximum Working Pressure

4 - 8 Bar Pilot Pressure

-50°C to +140°C

Normally Closed

DN 15

Ø13.0mm Nominal Bore

Cv: 3.0

'Floating Seat'

Weight: 7.1 Kg (Stainless Steel)

The PSV15 is both compact and robust in construction. High spring force, and a pressure biased valve maximise sealing force, whilst the 'floating seat' ensures optimised concentricity between mating parts.

The valve has been designed to be used with a wide range of gasses and liquids. Component parts are precision machined and include fine finishes where required to ensure excellent leak tight integrity even with the most searching of mediums.

MATERIALS

Body	See product selector
Stem (main valve)	1.4404 (316L Stainless Steel)
Seat	See product selector
Back-up rings	PTFE
Valve Spring (Wetted)	316 Stainless Steel
O-rings	See product selector
Trim	A4 Stainless Steel

VALVE SYMBOL

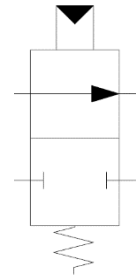

DIMENSIONS AND INSTALLATION DETAIL

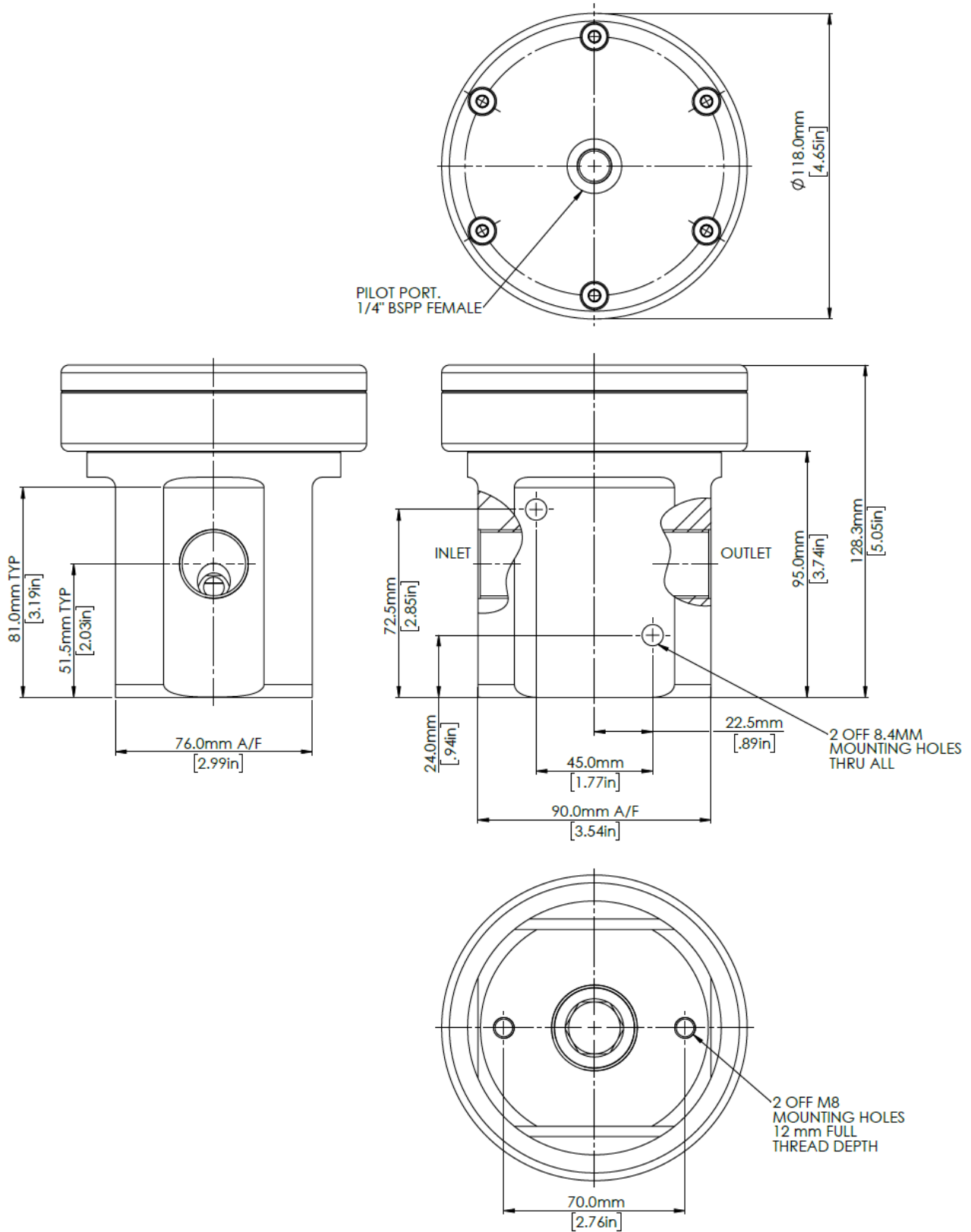

Product specification is subject to change without notice. Flow Products can assist the customer through the product selection process on a recommendation basis only, it is the user who must ensure the product is suitable for their application.

FULL COPYRIGHT © AND DESIGN RIGHT HELD BY FLOW PRODUCTS. ALL RIGHTS RESERVED. THIS DOCUMENT MUST NOT BE COPIED OR MODIFIED IN ANY WAY.

Document number: CAT-017. Revision: 1.

MODEL CODE CONFIGURATOR COMPLETE VALVES

Product Type -	Porting Size -	Porting Type -	Material -	Seal Material -	Seat Material -
PSV15 -	1 (1/2")	FB (BSPP Female)	1 (Aluminium)	1 (EPDM) -50°C to +140°C	1 (Nylon)
	2 (3/4")	FN (NPT Female)	2 (Brass)	2 (FKM) -20°C to +140°C	2 (Peek)
	3 (1")		3 (Stainless Steel)	3 (NBR) -30°C to +100°C	
			4 (Aluminium Bronze)	4 (HNBR) -35°C to +140°C	

Example part number: PSV15 – 2 – FB – 3 – 3 – 2

Other options available on request. Please contact Flow Products

Maximum working pressure

Stainless Steel: Limited to 500 Bar MWP.

Brass: Limited to 400 Bar MWP.

Aluminium: Limited to 400 Bar MWP.

Aluminium Bronze: Limited to 500 Bar MWP.

BSPP Ports: Limited to 400 Bar MWP.

NPT Ports: Limited to 500 Bar MWP.

SERVICE KITS

Product Type -	Seal Material -	Seat Material
PSV15 -	1 (EPDM)	1 (Nylon)
	2 (FKM)	2 (Peek)
	3 (NBR)	
	4 (HNBR)	

Example part number: PSV15 – 3 – 2