

## BACK PRESSURE DOME VALVES

### BPD25L

### VALVE SYMBOL

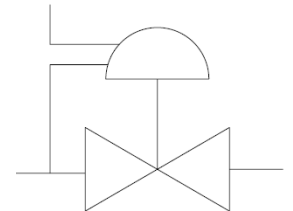

Gas or Liquid

Internal and External  
Dome Loading

0.5 - 75 Bar Set  
Pressure Range

-50°C to +140°C

Easy to adjust set  
pressure

DN 25

Ø25mm Nominal  
Bore

Weight: 13.1Kg  
(Aluminium Alloy)

The Low-pressure BPD25L Back Pressure Valve offers high-flow, as well as a wide set pressure range.

The seat and valve design ensure a smooth and controlled pressure relief and excellent re-seat characteristics due to virtually zero hysteresis.

The valve has been designed to be used with a wide range of gasses and liquids. Component parts are precision machined and include fine finishes where required to ensure excellent leak tight integrity even with the most searching of mediums.

### MATERIALS

|                       |                               |
|-----------------------|-------------------------------|
| Body                  | See product selector          |
| Stem (main valve)     | 1.4404 (316L Stainless Steel) |
| Seat                  | See product selector          |
| Back-up rings         | PTFE                          |
| Valve Spring (Wetted) | 316 Stainless Steel           |
| O-rings               | See product selector          |
| Trim                  | A4 Stainless Steel            |

## DIMENSIONS AND INSTALLATION DETAIL

Shown with 1-1/2" BSPP PORTS

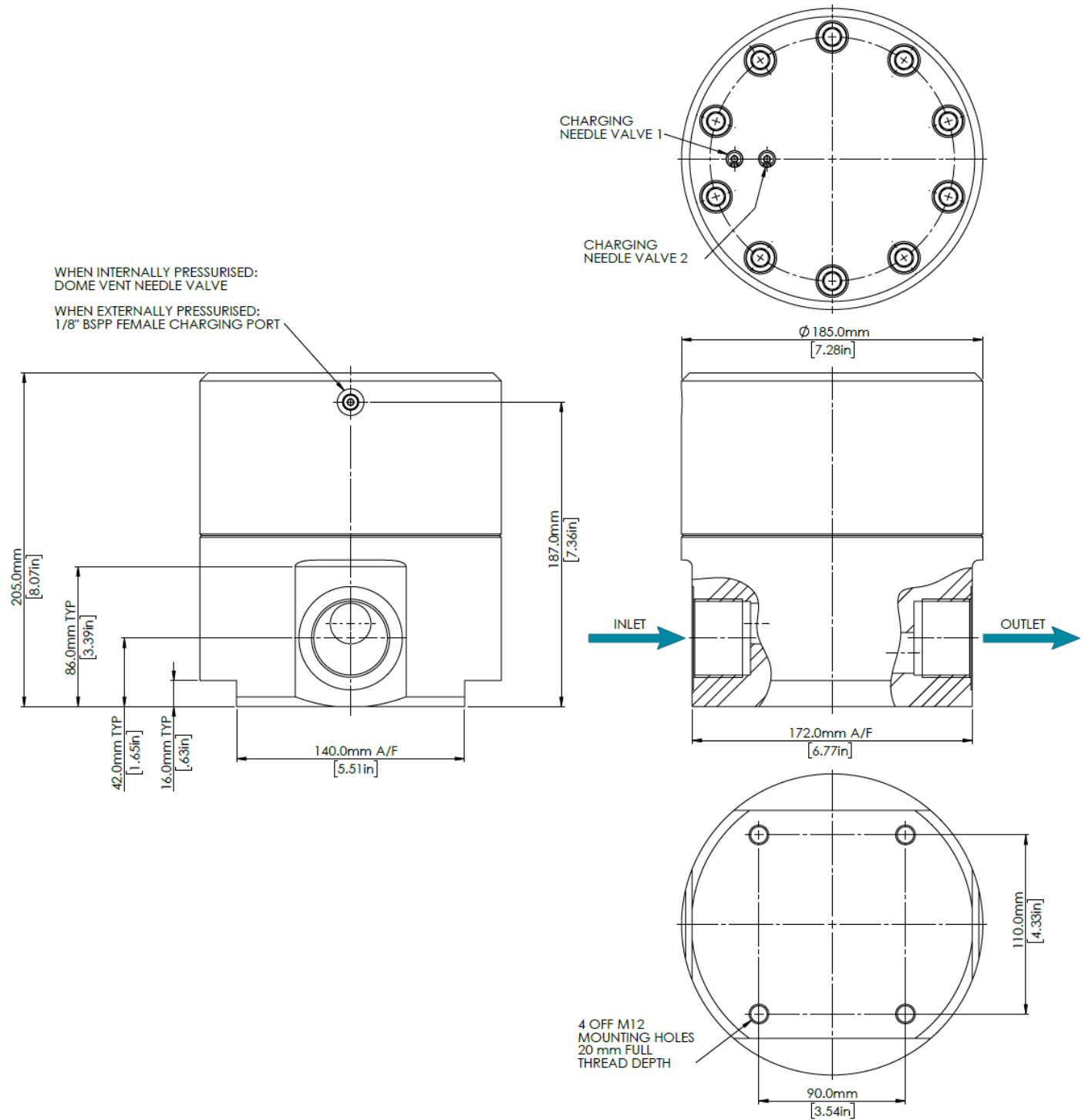

Product specification is subject to change without notice. Flow Products can assist the customer through the product selection process on a recommendation basis only, it is the user who must ensure the product is suitable for their application.

FULL COPYRIGHT © AND DESIGN RIGHT HELD BY FLOW PRODUCTS. ALL RIGHTS RESERVED. THIS DOCUMENT MUST NOT BE COPIED OR MODIFIED IN ANY WAY.

Document number: CAT-029. Revision: 1.

## MODEL CODE CONFIGURATOR COMPLETE VALVES

| Product Type - | Set Pressure Range - | Porting Size - | Porting Type -   | Material -           | Seal Material -          | Seat Material | Inlet Gauge Port         |
|----------------|----------------------|----------------|------------------|----------------------|--------------------------|---------------|--------------------------|
| BPD25L -       | 1 (0.5 – 75 Bar)     | 1 (1-1/2")     | FB (BSPP Female) | 1 (Aluminium)        | 1 (EPDM) -50°C to +140°C | 1 (EPDM)      | 1 (No Gauge Port)        |
|                |                      | 2 (2")         | FN (NPT Female)  | 2 (Brass)            | 2 (FKM) -20°C to +140°C  | 2 (FKM)       | 2 (1/4" BSPP Gauge Port) |
|                |                      |                |                  | 3 (Stainless Steel)  | 3 (NBR) -30°C to +100°C  | 3 (NBR)       |                          |
|                |                      |                |                  | 4 (Aluminium Bronze) | 4 (HNBR) -35°C to +140°C | 4 (HNBR)      |                          |

*Example part number: BPD25L – 1 – 1 – FB – 4 – 3 – 3 – 1*

*Other options available on request. Please contact Flow Products*

### Maximum working pressure

All versions: Limited to 75 Bar MWP.

## SERVICE KITS

| Product Type - | Seal Material - | Seat Material |
|----------------|-----------------|---------------|
| BPD25L -       | 1 (EPDM)        | 1 (EPDM)      |
|                | 2 (FKM)         | 2 (FKM)       |
|                | 3 (NBR)         | 3 (NBR)       |
|                | 4 (HNBR)        | 4 (HNBR)      |

*Example part number: BPD25L – 3 – 3*